

SERVICE BULLETIN

Beech

TITLE: LANDING GEAR - REPLACEMENT OF NOSE GEAR TRUNNION CHAMFERED WASHERS

1. Planning Information

A. Effectivity

(1) Airplanes

Beech Model A36 Bonanza, Serials E-3565 through E-3587, E-3590, E-3592, E-3593, E-3594, E-3598, E-3599, E-3601, E-3602, E-3604, E-3607 and E-3611 through E-3642.

If you are no longer in possession of the airplane, please forward this information to the present owner.

(2) Spares

None.

B. Reason

This Service Bulletin is being issued because Raytheon Aircraft Company (RAC) has received reports of landing gear trunnion nuts not maintaining proper torque when the chamfered washer was not properly installed.

C. Description

This Service Bulletin provides instructions to remove existing P/N MS20002C6 chamfered washers and replace with P/N MS20002-6 flat washers under the MS21042L6 or MS20365-624 nut.

D. Compliance

Raytheon Aircraft Company recommends that this Service Bulletin be accomplished at the next scheduled inspection.

E. Approval

The engineering data contained in this Service Bulletin is FAA approved.

The export of these commodities, technology or software are subject to the US Export Administration Regulations. Diversion contrary to U.S. law is prohibited. For guidance on export control requirements, contact the Commerce Department's Bureau of Export Administration at 202-482-4811 or at www.bxa.doc.gov.

Raytheon Aircraft Company (RAC) issues Service Information for the benefit of owners and fixed base operators in the form of two classes of Service Bulletins. The first class, Mandatory Service Bulletins (red border) includes changes, inspections and modifications that could affect safety or crashworthiness. RAC also issues Service Bulletins with no red border which are designated as either recommended or optional in the compliance section within the bulletin. In the case of recommended Service Bulletins, RAC feels the changes, modifications, improvements or inspections will benefit the owner/operator and although highly recommended, Recommended Service Bulletins are not considered mandatory at the time of issuance. In the case of Optional Service Bulletins, compliance with the changes, modifications, improvements or inspections is at the owner/operator's discretion.

Both classes are mailed to:

- (a) RAC Authorized Service Centers.
- (b) Owners of record on the FAA Aircraft Registration Branch List and the RAC International Owner Notification/Registration Service List.
- (c) Those having a publications subscription.

Information on Owner Notification Service or subscription can be obtained through any RAC Authorized Service Center. As Mandatory Service Bulletins and Service Bulletins are issued, temporary notification in the Service Bulletin Master Index should be made until the index is revised. Warranty will be allowed only when specifically defined in the Service Bulletin and in accordance with the RAC Warranty Policy.

Unless otherwise designated, RAC Mandatory Service Bulletins, Service Bulletins and RAC Kits are approved for installation on RAC airplanes in original or RAC modified configurations only. RAC Mandatory Service Bulletins, Service Bulletins and Kits may not be compatible with airplanes modified by STC installations or modifications other than RAC approved kits.

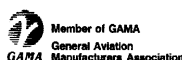

SERVICE BULLETIN

F. Manpower

The following information is for planning purposes only:

Estimated man-hours to inspect and change washer: 1.0 hour.

Estimated man-hours to inspect washer and change bushing: 3.0 hours.

Suggested number of men: 1 man.

The above is an estimate based on experienced, properly equipped personnel complying with this Service Bulletin. Occasionally, after work has started, conditions may be found which could result in additional man-hours.

G. Weight and Balance

None.

H. Electrical Load Data

Not changed.

I. Software Accomplishment Summary

Not applicable.

J. References

Bonanza Series Maintenance Manual, Chapters 7 and 32.

K. Publications Affected

None.

L. Interchangeability of Parts

Not applicable.

M. Warranty Credit

Warranty credit for labor and parts to the extent noted under MANPOWER and MATERIAL will be allowed on all affected airplanes.

Warranty coverage offered in this Service Bulletin will expire 12 months from the last day of the month this Service Bulletin is issued. After that date, the owner/operator assumes the responsibility for compliance cost. Raytheon Aircraft Company reserves the right to void warranty coverage in the area affected by this Service Bulletin until the date the Service Bulletin is accomplished by a Raytheon Aircraft Company Authorized Service Center.

All warranty work must be accomplished by a Raytheon Aircraft Authorized Service Center rated to perform maintenance on the specific model of Beechcraft Airplane.

All warranty reimbursements are handled through Raytheon Aircraft Company Authorized Service Centers. The owner/operator should arrange for an Authorized Service Center to perform the work and the Authorized Service Center must submit the standard Raytheon Aircraft Company warranty claim.

SERVICE BULLETIN

2. Material Information

A. Materials - Price and Availability

Contact a Raytheon Aircraft Authorized Service Center for information.

B. Industry Support

Not applicable.

C. Airplanes

The following parts required for this modification may be ordered through a Raytheon Aircraft Authorized Service Center or RAPID:

Part Number	Description	Quantity Per Airplane
MS20002-6	Flat Washer	2
45-825011	Grip Bushing	As Required
MS21042L6 or MS20365-624	Nut	2

Raytheon Aircraft Company expressly reserves the right to supersede, cancel and/or declare obsolete, without prior notice, any parts or publications that may be referenced in this Service Bulletin.

D. Spares

Not applicable.

E. Reidentified Parts

None.

F. Tooling - Price and Availability

Not applicable.

3. Accomplishment Instructions

This Service Bulletin shall be accomplished as follows:

NOTE

Should any difficulty be encountered in accomplishing this Service Bulletin, contact Raytheon Aircraft Company at 1-800-429-5372 or 316-676-3140.

SERVICE BULLETIN

A. Airplane

WARNING

Observe all Warnings and Cautions contained in the aircraft manuals referenced in this Service Bulletin.

Whenever any part of this system is dismantled, adjusted, repaired or renewed, detailed investigation must be made on completion to make sure that distortion, tools, rags or any other loose articles or foreign matter that could impede the free movement and safe operation of the system are not present, and that the systems and installations in the work area are clean.

- (1) Remove all power from the airplane and disconnect the battery. Display warning notices prohibiting reconnection of airplane electrical power.
- (2) Jack aircraft in accordance with Bonanza Series Maintenance Manual, Chapter 7.
- (3) Remove and discard the P/N MS21042L6 or MS20365-624 nut from the nose gear trunnion and inspect the P/N MS20002C6 chamfered washer to see if the countersunk side is facing toward the nut. Refer to Figure 1 for the locations of nose gear trunnion hardware.
 - (a) If the countersunk side of the washer is facing toward the nut, replace with P/N MS20002-6 flat washer. Install new P/N MS21042L6 or MS20365-624 nut and torque to 150 - 200 in. lbs.
 - (b) If the countersunk side of the washer is not facing toward the nut, replace P/N 45-825011 bushing with new bushing in accordance with Bonanza Series Maintenance Manual, Chapter 32. Install P/N MS20002-6 flat washer. Install new P/N MS21042L6 or MS20365-624 nut and torque to 150 - 200 in. lbs.
- (4) Reconnect the airplane battery, remove warning notices and restore power.
- (5) Perform functional check of the nose landing gear in accordance with Bonanza Series Maintenance Manual, Chapter 32.
- (6) Remove aircraft from jacks in accordance with Bonanza Series Maintenance Manual, Chapter 7.
- (7) Ensure all work areas are clean and clear of tools and miscellaneous items of equipment.
- (8) Return airplane to service.

B. Spares

Not applicable.

C. Record of Compliance

Upon completion of this Service Bulletin, make an appropriate maintenance record entry.

SERVICE BULLETIN

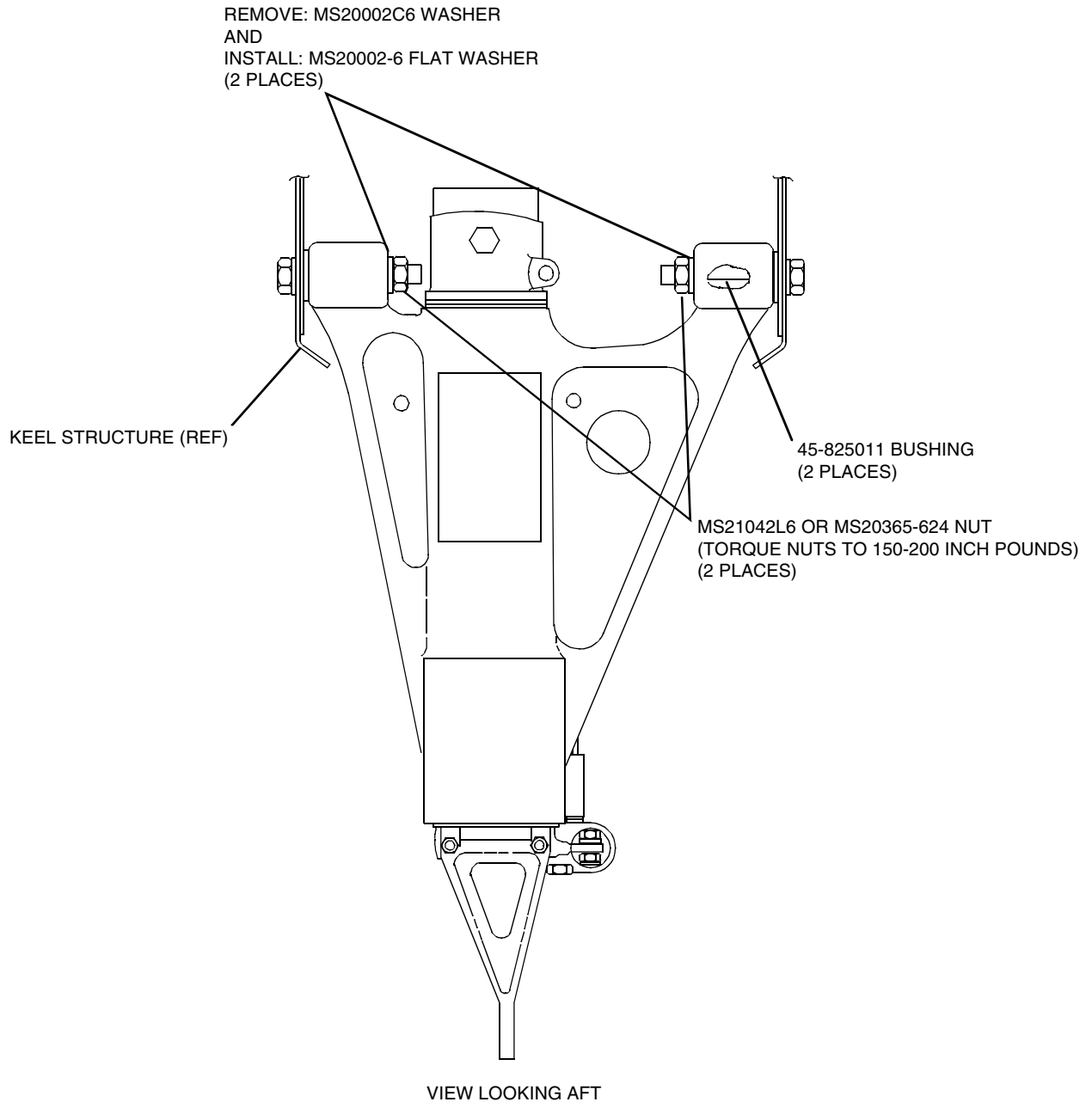

B374701.AI

Figure 1
Nose Gear Trunnion Hardware Location