

MODEL 35 THRU G35 PARTS CATALOG

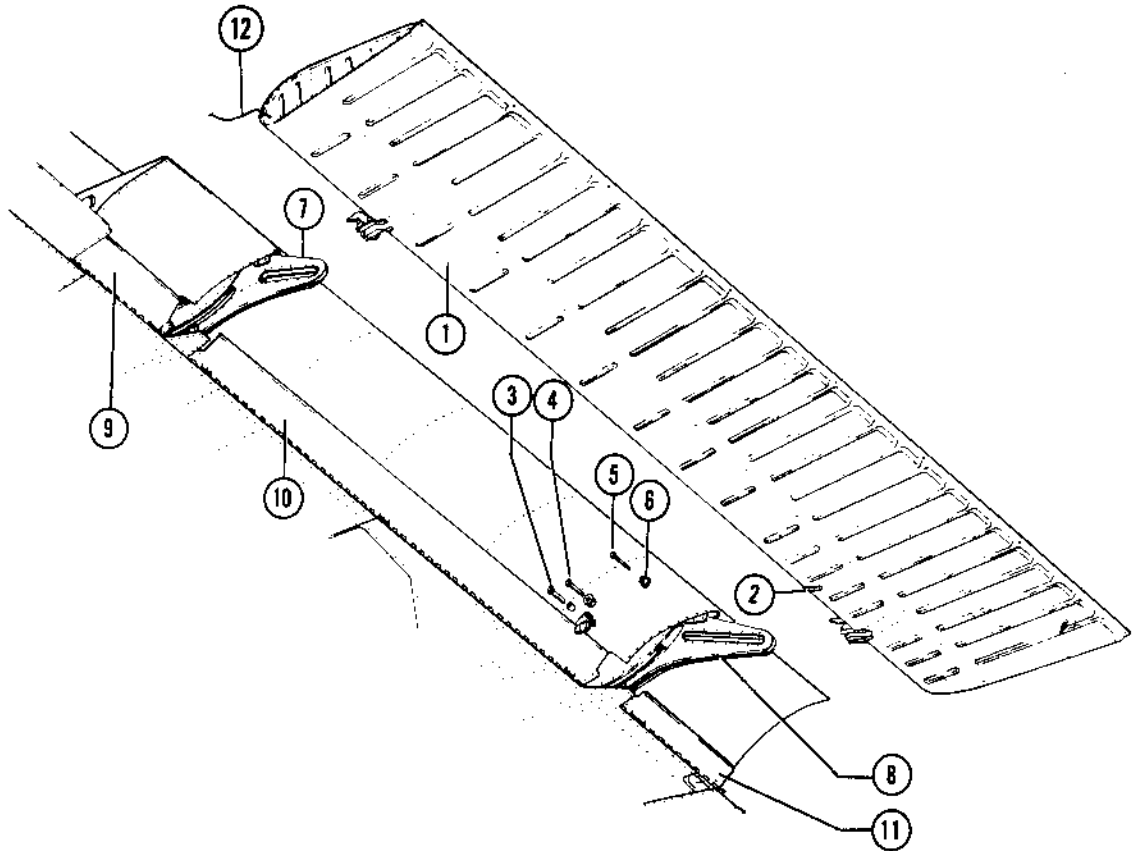

Figure 11. Flap, Flap Track and Flap Gap Doors

FIG. & INDEX NO.	PART NO.								UNITS PER ASSY	USABLE ON CODE	
		1	2	3	4	5	6	7			
11	35-165050-605	FLAP ASSY,LH.	1	
- 1	35-165050-607	FLAP ASSY,LH.	1	ABCD
	35-165050-606	FLAP ASSY,RH.	1	EFG
- 2	AN520-10-8	• SCREW,ACTUATOR BRACKET ATTACHING.	3	
	100951-5-007-02	• WASHER.	3	
	A6914-1024-1	• PLATE,ACCESS /TIN/.	4	
- 3	AN4-12A	BOLT,LH FLAP ACTUATOR	1	
	AN4-10A	BOLT,RH FLAP ACTUATOR	1	
	100801S5-0437	BUSHING	1	
	100801S5-0062	BUSHING,/LH SIDE ONLY/.	2	
	105090-091-4-016	WASHER,/LH SIDE ONLY/.	2	
	AN960-416L	WASHER,LH	1	
	AN960-416	WASHER,RH	1	
	AN365-428	NUT	1	
- 4	AN3-21A	BOLT,AFT FLAP ATTACHING	2	
- 5	AN3-11A	BOLT,FWD FLAP ATTACHING	2	
	AN960-10	WASHER.	4	
	AN365-1032	NUT	4	
- 6	35-165004	ROLLER ASSY,FLAP TRACK.	4	
- 7	35-115052	TRACK,OUTBD FLAP LH	1	
	35-115052-1	TRACK,OUTBD FLAP RH	1	
- 8	35-115301-601	TRACK,INBD FLAP LH.	1	

MODEL 35 THRU G35 PARTS CATALOG

FIG. & INDEX NO.	PART NO.	DESCRIPTION	UNITS PER ASSY	USABLE ON CODE		
					1	2
11	35-115301-602	TRACK,INBD FLAP RH.	1	ABCDE1 E2FG		
	45-115066-2	TRACK,INBD FLAP RH.	1			
	35-115030-14	STOP,RUBBER	2	A3		
- 9	35-115240-6	DOOR ASSY,FLAP GAP LH OUTBD	1	A3		
	35-115240-7	DOOR ASSY,FLAP GAP RH OUTBD	1	A3		
- 10	35-115240-4	DOOR ASSY,FLAP GAP LH CENTER.	1	A3		
	35-115240-5	DOOR ASSY,FLAP GAP RH CENTER.	1	A3		
- 11	35-115240-2	DOOR ASSY,FLAP GAP LH INBD.	1	A3		
	35-115240-3	DOOR ASSY,FLAP GAP RH INBD.	1	A3		
	35-115265	SKIN,TRAILING EDGE LH WING /REPLACES 35-115240/	1	A4BCDEFG		
	35-115265-1	SKIN,TRAILING EDGE RH WING /REPLACES 35-115240/	1	A4BCDEFG		
	104215-01130	PIN,INBD GAP DOOR HINGE	1	A3		
	105774C063-07516	PIN,OUTBD GAP DOOR HINGE.	1	A3		
	45-361118	BRACKET,LH FLAP LIMIT SWITCH.	1	E2FG		
- 12	AN749-1-6	JUMPER,BONDING.	1			

A3 code are Serial #'s D-1 thru D-1115